

MODEL 1250 — OIL COOLER OR HEATER

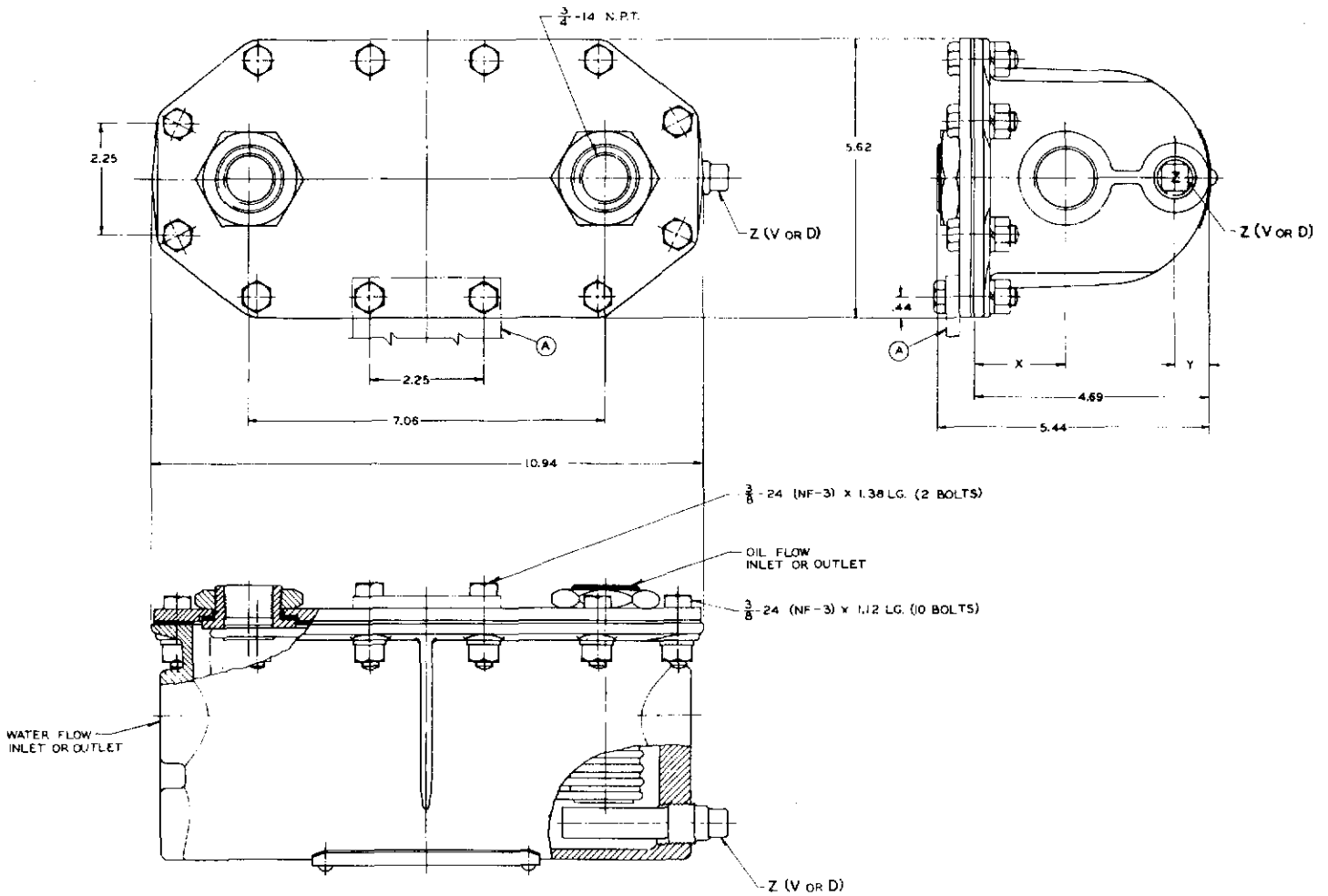

NOTES:

COMMERCIAL MARINE TYPE SHOWN

INDUSTRIAL TYPE — PIPE PLUG REPLACES  
ZINC ELECTRODE

(A) SUGGESTED APPLICATION OF  
MOUNTING BRACKET.

Z (V or D) — ZINC ELECTRODE (VENT OR DRAIN)

WEIGHT DRY 25 LBS. APPROX.

WEIGHT WET 29 LBS. APPROX.

WATER N.P.T. SIZE	$\frac{3}{4}$	1	$1\frac{1}{4}$	$1\frac{1}{2}$	2	
X DIMENSION	1.81	1.81	2.16	2.16	2.34	
Y DIMENSION	.72	.72	.72	.72	.54	

OIL N.P.T. SIZE -  $\frac{3}{4}$