

MODEL 1080 — OIL COOLER OR HEATER

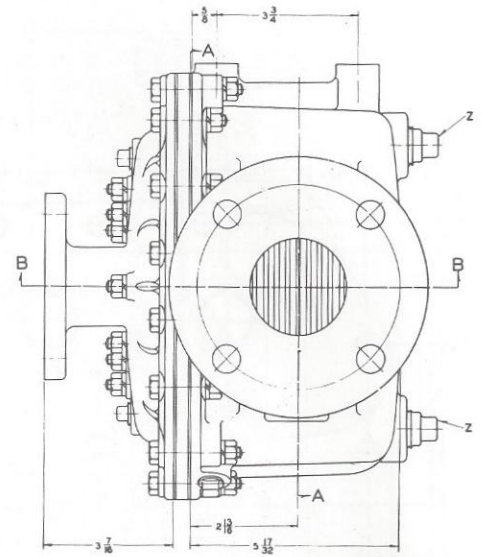
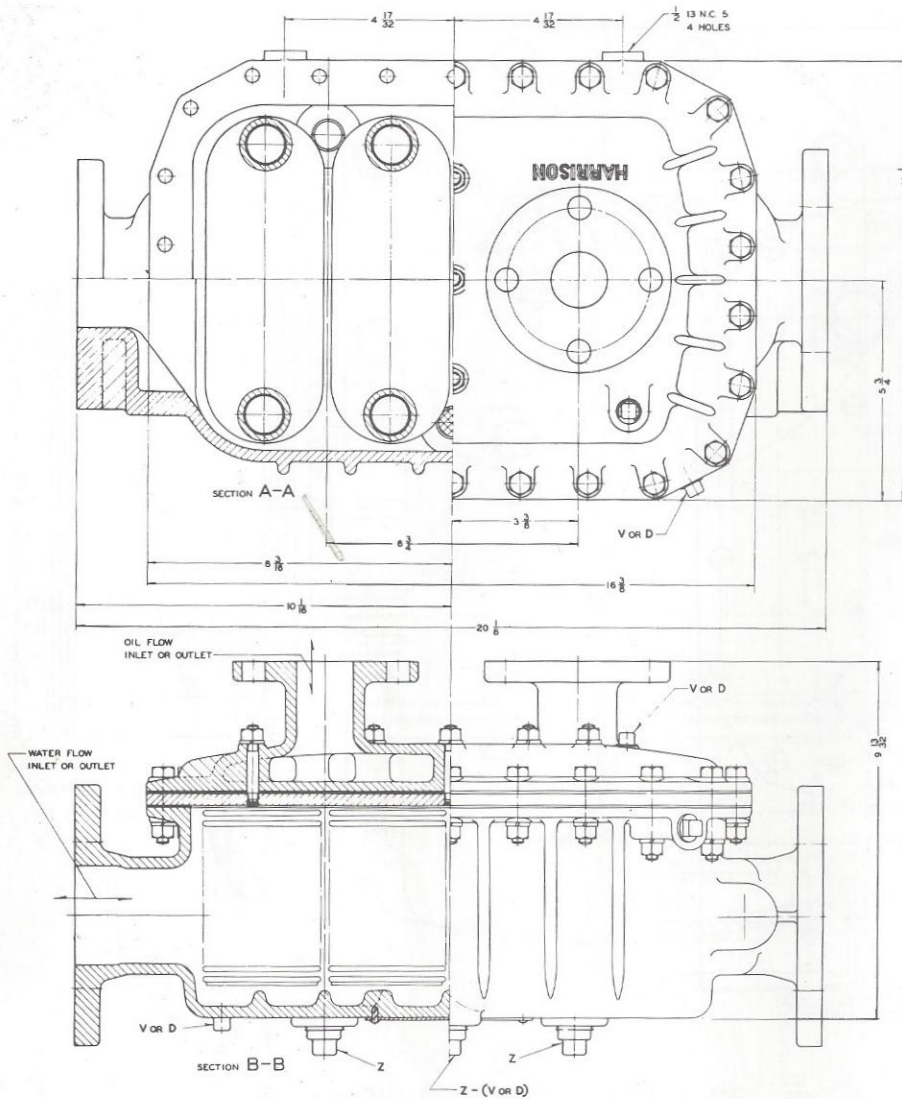

NOTES:

COMMERCIAL MARINE TYPE SHOWN

INDUSTRIAL TYPE — PIPE PLUG REPLACES ZINC ELECTRODE

Z (V OR D) — ZINC ELECTRODE (VENT OR DRAIN)

WEIGHT DRY 140 LBS. APPROX.

WEIGHT WET 162 LBS. APPROX.

INDUSTRIAL TYPE						
AVAILABLE AMERICAN FLANGES						
OIL	WATER	NO. HOLES	FLANGE SIZES			I. D.
			B. C.	O. D.	I. D.	
	2	4	4 3/4	6	2	
1 1/2		4	3 7/8	5	1 1/2	
2		4	4 3/4	6	2	

COMMERCIAL MARINE TYPE						
AVAILABLE AMERICAN FLANGES						
OIL	WATER	NO. HOLES	FLANGE SIZES			I. D.
			B. C.	O. D.	I. D.	
	2	4	4 3/4	6	2	
	2 1/2	4	5 1/2	7	2 1/2	
1 1/2		4	3 7/8	5	1 1/2	
2		4	4 3/4	6	2	