

MODEL 1070 — OIL COOLER OR HEATER

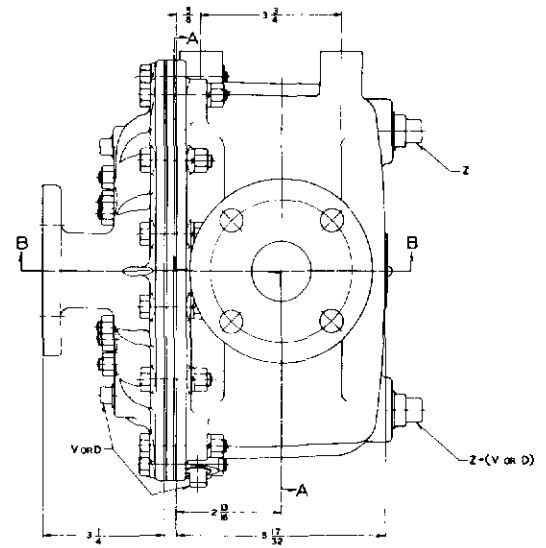
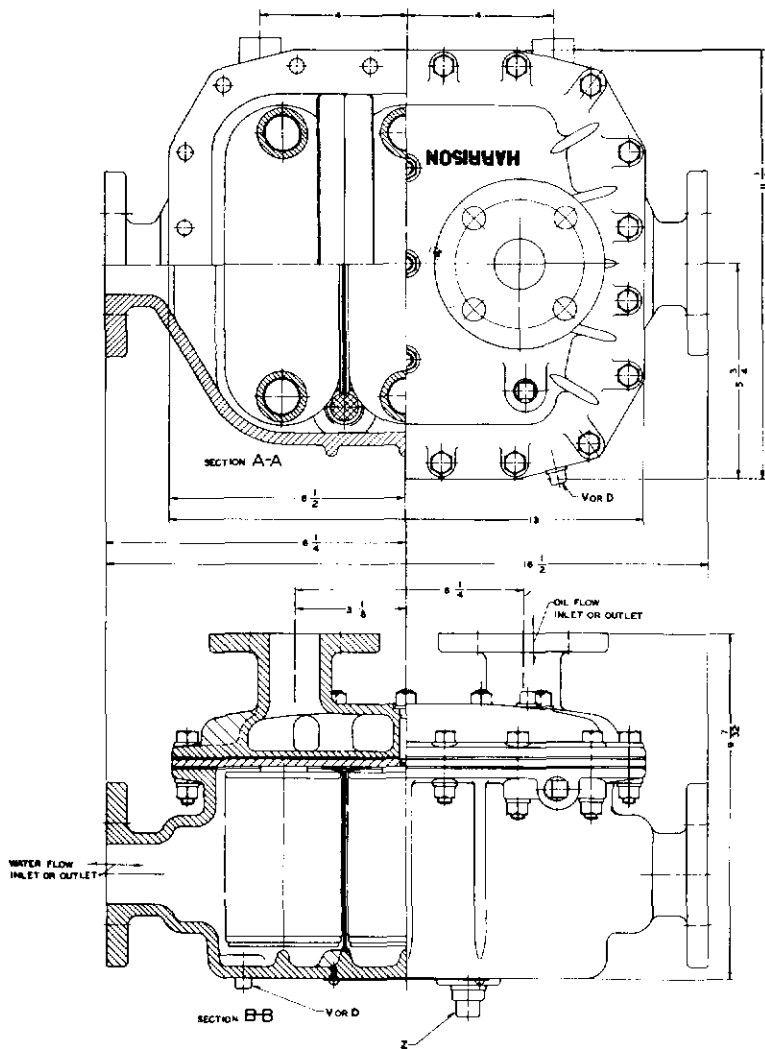

NOTES:

COMMERCIAL MARINE TYPE SHOWN

INDUSTRIAL TYPE — PIPE PLUG REPLACES ZINC ELECTRODE

Z (V OR D) — ZINC ELECTRODE (VENT OR DRAIN)

WEIGHT DRY 126 LBS. APPROX.

WEIGHT WET 141 LBS. APPROX.

INDUSTRIAL TYPE					
AVAILABLE AMERICAN FLANGES					
OIL	WATER	FLANGE SIZES			
		NO. HOLES	B.C.	O.D.	I.D.
1 1/4		4	3 1/2	4 5/8	1 1/4
	1 1/2	4	3 7/8	5	1 1/2

COMMERCIAL MARINE TYPE					
AVAILABLE AMERICAN FLANGES					
OIL	WATER	FLANGE SIZES			
		NO. HOLES	B.C.	O.D.	I.D.
1 1/4		4	3 1/2	4 5/8	1 1/4
	1 1/2	4	3 7/8	5	1 1/2